

ORSY

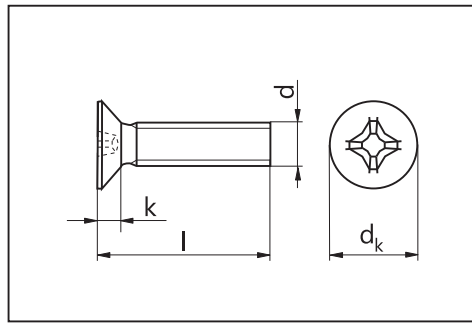

Senkschrauben mit Kreuzschlitz H nach DIN 965 (ISO 7046)

Stahl 4.8 blank
Stahl 4.8 verzinkt, blau passiviert
Stahl 4.8 verzinkt, gelb passiviert
Stahl 4.8 vernickelt

A2
A4

Nenn-Ø d	M 2	M 2,5	M 3	M 3,5	M 4	M 5	M 6	M 8	M 10
dk mm	3,8	4,7	5,6	6,5	7,5	9,2	11,0	14,5	18,0
k mm	1,2	1,5	1,65	1,93	2,2	2,5	3,0	4,0	5,0
Antrieb	H1	H1	H1	H2	H2	H2	H3	H4	H4



Sortiment



Kreuzschlitz-Gewindeschrauben,
DIN 7985/965, Stahl verzinkt, blau pass.



Artikel:

- 0046 4 x 10/16/20
- 0046 5 x 10/16/20
- 0046 6 x 10/16/20
- 0048 4 x 10/16/20
- 0048 5 x 10/16/20
- 0048 6 x 10/16/20
- Tiefziehteil, Art.-Nr. 0955 801 8

Art.-Nr. 0964 046

Nenn-Ø d	Länge l mm	Stahl 4.8 blank Art.-Nr.	VE/St.	Stahl 4.8 vz., blau pass. Art.-Nr.	VE/St.	Stahl 4.8 vz., gelb pass. Art.-Nr.	VE/St.	Stahl 4.8 vernickelt Art.-Nr.	VE/St.	A2 Art.-Nr.	VE/St.	A4 Art.-Nr.	VE/St.
M 2	3		500/2000	0048 2 3	2000		2000		2000	0281 2 3	1000		
	4	0048 02 4		0048 2 4		0281 2 4							
	5	0048 02 5		0048 2 5									
	6	0048 02 6		0048 2 6		0281 2 8							
	8	0048 02 8		0048 2 8									
	10	0048 02 10		0048 2 10									
	12	0048 02 12		0048 2 12									
	14	0048 02 14		0048 2 14									
M 2,5	4	0048 025 4	2000	0048 25 4	500/1000	0048 125 04	2000	0048 525 4	2000	0281 25 4	1000		
	5	0048 025 5		0048 25 5		0048 125 05		0048 525 5		0281 25 5			
	6	0048 025 6		0048 25 6		0048 125 06		0048 525 6		0281 25 6			
	8	0048 025 8		0048 25 8		0048 125 08		0048 525 8		0281 25 8			
	10	0048 025 10		0048 25 10		0048 125 10		0048 525 10					
	12	0048 025 12		0048 25 12		0048 125 12		0048 525 12					
	16	0048 025 16		0048 25 16		0048 125 16		0048 525 16					
	20	0048 025 20		0048 25 20		0048 125 20		0048 525 20					
M 3	4	0048 03 4	1000	0048 3 4	100/500	0048 10 304	1000/2000	0048 53 4	2000	0281 3 4	500/1000		1000
	5	0048 03 5		0048 3 5		0048 10 305		0048 53 5		0281 3 5			
	6	0048 03 6		0048 3 6		0048 10 306		0048 53 6		0281 3 6			
	8	0048 03 8		0048 3 8		0048 10 308		0048 53 8		0281 3 8			
	10	0048 03 10		0048 3 10		0048 10 310		0048 53 10		0281 3 10			
	12	0048 03 12		0048 3 12		0048 10 312		0048 53 12		0281 3 12			
	14	0048 03 14		0048 3 14						0281 3 14			
	16	0048 03 16		0048 3 16		0048 10 316		0048 53 16		0281 3 16			
	18	0048 03 18		0048 3 18									
	20	0048 03 20		0048 3 20		0048 10 320		0048 53 20		0281 3 20			
	22	0048 03 22		0048 3 22									
	25	0048 03 25		0048 3 25		0048 10 325		0048 53 25		0281 3 25			
	28	0048 03 28		0048 3 28									
	30	0048 03 30		0048 3 30		0048 10 330		0048 53 30		0281 3 30			
	35	0048 03 35		0048 3 35		0048 10 335		0048 53 35		0281 3 35			
	40	0048 03 40		0048 3 40		0048 10 340		0048 53 40		0281 3 40			

Nenn-Ø d	Länge l mm	Stahl 4.8 blank Art.-Nr.	VE/St.	Stahl 4.8 vz., blau pass. Art.-Nr.	VE/St.	Stahl 4.8 vz., gelb pass. Art.-Nr.	VE/St.	Stahl 4.8 vernickelt Art.-Nr.	VE/St.	A2  Art.-Nr.	VE/St.	A4  Art.-Nr.	VE/St.					
M 3	45	0048 03 45	1000	0048 3 45	1000	0048 10 345	1000	0048 53 45	1000									
	50	0048 03 50		0048 3 50	100	0048 10 350		0048 53 50										
	60	0048 03 60	500	0048 3 60	500	0048 10 360	500											
M 3,5	6	0048 035 6			2000													
	8	0048 035 8		0048 35 8														
	10	0048 035 10		0048 35 10														
	12	0048 035 12		0048 35 12														
	16	0048 035 16		0048 35 16														
M 4	20	0048 035 20	2000	0048 35 20	100/500	0048 10 405	2000	0048 54 5	2000	0281 4 5	1000		1000					
	5	0048 04 5		0048 4 5		0048 10 406		0048 54 6		0281 4 6	200/500			0298 4 6				
	6	0048 04 6		0048 4 6		0048 10 408		0048 54 8		0281 4 8				0298 4 8				
	8	0048 04 8		0048 4 8		0048 10 410		0048 54 10		0281 4 10	0298 4 10							
	10	0048 04 10		0048 4 10		0048 10 412		0048 54 12		0281 4 12	0298 4 12							
	12	0048 04 12		0048 4 12		0048 10 414		0048 54 14										
	14	0048 04 14		0048 4 14		0048 10 416		0048 54 16		0281 4 16	200/500			0298 4 16				
	16	0048 04 16		0048 4 16														
	18	0048 04 18		0048 4 18		250		0048 54 18		0281 4 18	1000							
	20	0048 04 20		0048 4 20		100/250/1000		0048 10 420		0048 54 20	200/500			0298 4 20				
	22	0048 04 22		0048 4 22		2000								0281 4 22	1000			
	25	0048 04 25		0048 4 25		100/250		0048 10 425		1000	0048 54 25			1000	0281 4 25	200/500	0298 4 25	
	28	0048 04 28		0048 4 28		1000												
	30	0048 04 30		0048 4 30		1000		0048 10 430			0048 54 30			1000	0281 4 30	200/500	0298 4 30	
	35	0048 04 35		0048 4 35		100/250		0048 10 435			0048 54 35			1000	0281 4 35	500	0298 4 35	500
40	0048 04 40	0048 4 40	100/250	0048 10 440		0048 54 40	1000	0281 4 40	200	0298 4 40								
45	0048 04 45	0048 4 45	500	0048 10 445	500	0048 54 45		0281 4 45										
50	0048 04 50	0048 4 50	100/250	0048 10 450		0048 54 50		0281 4 50	500	0298 4 50								
55	0048 04 55	0048 4 55																
60	0048 04 60	0048 4 60	500	0048 10 460	500	0048 54 60	1000	0281 4 60	500	0298 4 60								
70	0048 04 70	0048 4 70	100															
80	0048 04 80	0048 4 80																
90	0048 04 90	0048 4 90	200		200													
100	0048 04 100	0048 4 100																
105				0048 4 105	100													
M 5	6	0048 05 6	2000	0048 5 6	2000	0048 10 506	2000		2000	0281 5 6	500		500					
	8	0048 05 8		0048 5 8	100/250/1000	0048 10 508		0048 55 8		0281 5 8								
	10	0048 05 10		0048 5 10	100/250	0048 10 510		0048 55 10		0281 5 10	100/500			0298 5 10				
	12	0048 05 12		0048 5 12	100/250/1000	0048 10 512	100/1000	0048 55 12	200	0281 5 12		0298 5 12						
	14	0048 05 14		0048 5 14	1000					0281 5 14	500							
	16	0048 05 16		0048 5 16	250/1000	0048 10 516		0048 55 16		0281 5 16		0298 5 16						
	18	0048 05 18		0048 5 18	1000					0281 5 18	100/500							
	20	0048 05 20		0048 5 20	100/250	0048 10 520		0048 55 20		0281 5 20		0298 5 20						
	22	0048 05 22		0048 5 22	1000		1000		1000	0281 5 22	500							
	25	0048 05 25		0048 5 25	100	0048 10 525		0048 55 25		0281 5 25	100/500	0298 5 25						
	28	0048 05 28		0048 5 28	1000													
	30	0048 05 30		0048 5 30	100	0048 10 530		0048 55 30		0281 5 30		0298 5 30						
	35	0048 05 35		0048 5 35	100	0048 10 535	500	0048 55 35		0281 5 35	100/500	0298 5 35						
	40	0048 05 40		0048 5 40	100/500	0048 10 540	4500	0048 55 40		0281 5 40		0298 5 40						
	45	0048 05 45		0048 5 45	100	0048 10 545	500	0048 55 45	500	0281 5 45	200	0298 5 45						
50	0048 05 50		0048 5 50	100	0048 10 550		0048 55 50		0281 5 50		0298 5 50							
55	0048 05 55		0048 5 55	100/500														
60	0048 05 60		0048 5 60		0048 10 560	200	0048 55 60	200	0281 5 60	100	0298 5 60							
65	0048 05 65		0048 5 65						0281 5 65	200								
70	0048 05 70		0048 5 70		0048 10 570	200			0281 5 70	100	0298 5 70							
75	0048 05 75		0048 5 75	200														
80	0048 05 80		0048 5 80						0281 5 80	200								
90	0048 05 90		0048 5 90															
100	0048 05 100		0048 5 100															
M 6	8	0048 06 8	1000	0048 6 8	100/500	0048 10 608	1000	0048 56 8	1000	0281 6 8	100	0298 6 8	200					
	10	0048 06 10		0048 6 10	100/250/1000	0048 10 610		0048 56 10		0281 6 10		0298 6 10						
	12	0048 06 12		0048 6 12		0048 10 612		0048 56 12		0281 6 12		0298 6 12						
	14	0048 06 14		0048 6 14	1000	0048 10 614				0281 6 14		200						
	16	0048 06 16		0048 6 16	1000	0048 10 616		1000		0048 56 16		0281 6 16		100	0298 6 16			
	18	0048 06 18		0048 6 18	100/250							0281 6 18		200				

Nenn- Ø d	Länge l mm	Stahl 4.8 blank Art.-Nr.	VE/St.	Stahl 4.8 vz., blau pass. Art.-Nr.	VE/St.	Stahl 4.8 vz., gelb pass. Art.-Nr.	VE/St.	Stahl 4.8 vernickelt Art.-Nr.	VE/St.	A2 	VE/St.	A4 	VE/St.	
M 6	20	0048 06 20	1000	0048 6 20	100/300	0048 10 620		0048 56 20	1000	0281 6 20	100	0298 6 20	200	
	22	0048 06 22	500	0048 6 22	500					0281 6 22	200			
	25	0048 06 25		0048 6 25	100/300	0048 10 625	500	0048 56 25	500	0281 6 25		0298 6 25		
	30	0048 06 30		0048 6 30		0048 10 630		0048 56 30		0281 6 30		0298 6 30		
	35	0048 06 35		0048 6 35		0048 10 635		0048 56 35		0281 6 35		0298 6 35		
	40	0048 06 40		0048 6 40		0048 10 640		0048 56 40		0281 6 40		0298 6 40		
	45	0048 06 45		0048 6 45		0048 10 645				0281 6 45		0298 6 45		
	50	0048 06 50		0048 6 50	100	0048 10 650	200	0048 56 50	200	0281 6 50		0298 6 50		
	55	0048 06 55		0048 6 55	200	0048 6 55				0281 6 55				0298 6 55
	60	0048 06 60		0048 6 60		0048 10 660	200	0048 56 60	200	0281 6 60		0298 6 60		
	65	0048 06 65		0048 6 65		200				0281 6 65				
	70	0048 06 70		0048 6 70		100				0281 6 70		0298 6 70		
	75	0048 06 75		0048 6 75		200								
	80	0048 06 80		0048 6 80		100				0281 6 80		0298 6 80		
90	0048 06 90	0048 6 90		50					0281 6 90		0298 6 90			
100	0048 06 100	0048 6 100								0298 6 100				
M 8	10			0048 8 10		100					0281 8 10	500		100
	12	0048 08 12	500	0048 8 12		100	0048 10 812	200/1000			0281 8 12			
	14	0048 08 14		0048 8 14		500								
	16	0048 08 16		0048 8 16		100	0048 10 816	500			0281 8 16		0298 8 16	
	18	0048 08 18		0048 8 18		500								
	20	0048 08 20		0048 8 20			0048 10 820	200/500			0281 8 20		0298 8 20	
	25	0048 08 25		0048 8 25		0048 10 825				0281 8 25		0298 8 25		
	30	0048 08 30		0048 8 30		0048 10 830				0281 8 30		0298 8 30		
	35	0048 08 35		0048 8 35	100	0048 10 835	200			0281 8 35		0298 8 35		
	40	0048 08 40		0048 8 40		0048 10 840				0281 8 40		0298 8 40		
	45	0048 08 45		0048 8 45						0281 8 45		0298 8 45		
	50	0048 08 50		0048 8 50		0048 10 850				0281 8 50				
	55	0048 08 55		0048 8 55	200	0048 8 55				0281 8 55				
	60	0048 08 60		0048 8 60		50				0281 8 60		0298 8 60	100	
65	0048 08 65	0048 8 65		100										
70	0048 08 70	0048 8 70						0281 8 70						
80	0048 08 80	0048 8 80	50					0281 8 80						
90	0048 08 90	0048 8 90												
100	0048 08 100	0048 8 100	100					0281 8 100						
M 10	16	0048 010 16		0048 10 16		200								
	20	0048 010 20	100	0048 10 20							0281 10 20			
	25	0048 010 25	200	0048 10 25		100					0281 10 25			
	30	0048 010 30		0048 10 30						0281 10 30				
	35	0048 010 35		0048 10 35						0281 10 35				
	40	0048 010 40		0048 10 40		200	0048 110 40	100		0281 10 40				
	45	0048 010 45		0048 10 45										
	50	0048 010 50	100	0048 10 50					0281 10 50					
60	0048 010 60	0048 10 60		100				0281 10 60						
70	0048 010 70	0048 10 70												
80	0048 010 80	0048 10 80												