

Linsen- schrauben

mit Kreuzschlitz H nach DIN 7985 (ISO 7045)

Stahl 4.8 blank
Stahl 4.8 verzinkt, blau passiviert
Stahl 4.8 verzinkt, gelb passiviert
Stahl 4.8 vernickelt

A2
A4

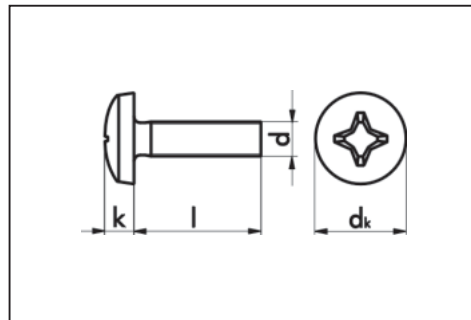
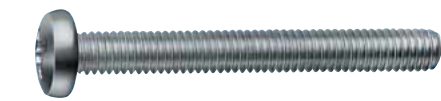



ORSY

Nenn-Ø d	M 2	M 2,5	M 3	M 3,5	M 4	M 5	M 6	M 8	M 10
dk mm	4,0	5,0	6,0	7,0	8,0	10,0	12,0	16,0	20,0
k mm	1,6	2,0	2,4	2,7	3,1	3,8	4,6	6,0	7,5
	H1	H1	H1	H2	H2	H2	H3	H4	H4

Nenn-Ø d	Länge l mm	Stahl 4.8 blank Art.-Nr.	VE/St.	Stahl 4.8 vz., blau pass. Art.-Nr.	VE/St.	Stahl 4.8 vz., gelb pass. Art.-Nr.	VE/St.	Stahl 4.8 vernickelt Art.-Nr.	VE/St.	A2 Art.-Nr.	VE/St.	A4 Art.-Nr.	VE/St.								
M 2	3	0046 02 3	2000	0046 2 3	2000	0046 102 04	2000	0046 92 4	2000	0283 2 6	1000	0283 2 8	500								
	4	0046 02 4		0046 2 4		0046 102 05		0046 92 5						0283 2 10							
	5	0046 02 5		0046 2 5		0046 102 06		0046 92 6													
	6	0046 02 6		0046 2 6		0046 102 08		0046 92 8													
	8	0046 02 8		0046 2 8		0046 102 10		0046 92 10						0283 2 12							
	10	0046 02 10		0046 2 10		0046 102 12		0046 92 12													
	12	0046 02 12		0046 2 12																	
	14	0046 02 14		0046 2 14																	
	16	0046 02 16		0046 2 16				0046 102 16						0046 92 16	2000	0283 2 16	1000				
20	0046 02 20	0046 2 20	0046 102 20	0046 92 20																	
M 2,5	3	0046 025 3	2000	0046 25 3	2000	0046 125 04	2000	0046 925 4	500/2000	0283 25 6	1000	0293 25 6	500								
	4	0046 025 4		0046 25 4		0046 125 05		0046 925 6						0283 25 8							
	5	0046 025 5		0046 25 5		0046 125 06		0046 925 8													
	6	0046 025 6		0046 25 6		0046 125 08		0046 925 10						0283 25 10							
	8	0046 025 8		0046 25 8		0046 125 10		0046 925 12													
	10	0046 025 10		0046 25 10		0046 125 12															
	12	0046 025 12		0046 25 12																	
	14	0046 025 14		0046 25 14		2000															
	16	0046 025 16		0046 25 16		500		0046 125 16						2000	0046 925 16	500/2000	0283 25 16	1000			
	18	0046 025 18		0046 25 18		2000															
	20	0046 025 20		0046 25 20		500/1000		0046 125 20						2000	0046 925 20	2000	0283 25 20	1000			
25	0046 025 25	0046 25 25	100/2000	0046 125 25	0046 925 25	0283 25 25															
30	0046 025 30	0046 25 30	2000			0046 925 30															
M 3	4	0046 03 4	2000	0046 3 4	100/500	0046 103 04	100	0046 93 4	2000	0283 3 4	500	0293 3 5	1000								
	5	0046 03 5		0046 3 5		0046 103 05	2000	0046 93 5		0283 3 5											
	6	0046 03 6		0046 3 6		0046 103 06	500/2000	0046 93 6		0283 3 6											
	8	0046 03 8		0046 3 8		0046 103 08		0046 93 8		0283 3 8											
	10	0046 03 10		0046 3 10		0046 103 10	1000/2000	0046 93 10		0283 3 10		500/1000									
	12	0046 03 12		0046 3 12		0046 103 12	500/2000	0046 93 12		0283 3 12				500							
	14	0046 03 14		0046 3 14			0046 103 14	2000		0046 93 14		2000									
	16	0046 03 16		0046 3 16			0046 103 16	500/2000		0046 93 16		500		0283 3 16	500	0293 3 16	1000				
	18	0046 03 18		0046 3 18		100/1000	0046 103 18	2000		0046 93 18		500/2000				0293 3 18	500				
	20	0046 03 20		0046 3 20		100/500/1000	0046 103 20	500		0046 93 20				0283 3 20	500	0293 3 20	1000				
	22	0046 03 22		0046 3 22		2000	0046 103 22	2000		0046 93 22		2000									
	25	0046 03 25		0046 3 25			0046 103 25	500/2000		0046 93 25		500/2000		0283 3 25	500	0293 3 25	1000				
	28	0046 03 28				100/500								0283 3 28	1000						
	30	0046 03 30		0046 3 30			0046 103 30	500/2000		0046 93 30		500/2000		0283 3 30	500	0293 3 30	1000				
	35	0046 03 35		0046 3 35		100	0046 103 35	250/1000		0046 93 35		1000		0283 3 35	1000	0293 3 35	500				
	40	0046 03 40		0046 3 40		100/250	0046 103 40			0046 93 40				0283 3 40							
	45	0046 03 45		0046 3 45		100	0046 103 45	250		0046 93 45											
	50	0046 03 50		0046 3 50		1000	0046 103 50	2000		0046 93 50				0283 3 50	1000						
55	0046 03 55	0046 3 55	500	0046 103 55	1000																
60	0046 03 60	0046 3 60																			

Nenn-Ø d	Länge l mm	Stahl 4.8 blank Art.-Nr.	VE/St.	Stahl 4.8 vz., blau pass. Art.-Nr.	VE/St.	Stahl 4.8 vz., gelb pass. Art.-Nr.	VE/St.	Stahl 4.8 vernickelt Art.-Nr.	VE/St.	A2 Art.-Nr.	VE/St.	A4 Art.-Nr.	VE/St.	
M 3,5	5	0046 035 5	2000	0046 35 5	200/2000			0046 935 6	2000					
	6	0046 035 6		0046 35 6										
	8	0046 035 8		0046 35 8										
	10	0046 035 10		0046 35 10										
	12	0046 035 12		0046 35 12										
	16	0046 035 16		0046 35 16										
	18	0046 035 18		0046 35 18										
	20	0046 035 20		0046 35 20										
	25	0046 035 25	0046 35 25											
	30	0046 035 30	1000	0046 35 30	1000									
M 4	4	0046 04 4	2000	0046 4 4	2000	0046 104 04	200/2000	0046 94 4	2000	0283 4 5	500			
	5	0046 04 5		0046 4 5	100/500/1000	0046 104 05	2000	0046 94 5						
	6	0046 04 6		0046 4 6	100/500	0046 104 06	1000/2000	0046 94 6	1000	0283 4 6	200/500		0293 4 6	1000
	8	0046 04 8		0046 4 8		0046 104 08	2000	0046 94 8	1000/2000	0283 4 8			0293 4 8	
	10	0046 04 10		0046 4 10	0046 104 10	1000/2000	0046 94 10	500/2000	0283 4 10	0293 4 10				
	12	0046 04 12		0046 4 12	100/250/1000	0046 104 12		0046 94 12	500/2000/5000	0283 4 12	0293 4 12			
	14	0046 04 14		0046 4 14	2000	0046 104 14	2000	0046 94 14	2000	0283 4 14	500			
	16	0046 04 16		0046 4 16	250/1000	0046 104 16	1000/2000	0046 94 16	500	0283 4 16	200/500	0293 4 16	1000	
	18	0046 04 18		0046 4 18	100/250/1000	0046 104 18	2000	0046 94 18	2000	0283 4 18	1000			
	20	0046 04 20		0046 4 20	250/1000	0046 104 20	1000/2000	0046 94 20		0283 4 20	200/500	0293 4 20	1000	
	22	0046 04 22		0046 4 22	1000	0046 104 22	1000	0046 94 22		0283 4 22	1000			
	25	0046 04 25		0046 4 25	100/250/1000	0046 104 25	1000/2000	0046 94 25	1000	0283 4 25	200/500	0293 4 25	500	
	28	0046 04 28		0046 4 28	1000	0046 104 28								
	30	0046 04 30		0046 4 30	100/250/1000	0046 104 30	1000	0046 94 30	1000	0283 4 30	200/500	0293 4 30	500	
	32	0046 04 32		0046 4 32	1000	0046 4 32	1000							
	35	0046 04 35		0046 4 35	100/250	0046 104 35	100/1000	0046 94 35	1000	0283 4 35	500	0293 4 35	500	
	38	0046 04 38		0046 4 38	1000									
	40	0046 04 40		0046 4 40	100/250	0046 104 40	250/1000	0046 94 40	1000	0283 4 40	500	0293 4 40	500	
	45	0046 04 45		0046 4 45		0046 104 45	500	0046 94 45	500	0283 4 45		0293 4 45		
	50	0046 04 50	0046 4 50	500	0046 104 50	100/500	0046 94 50	500	0283 4 50	500	0293 4 50	500		
55	0046 04 55	0046 4 55	0046 104 55		500									
60	0046 04 60	0046 4 60	0046 104 60			0046 94 60	500	0283 4 60	500					
65	0046 04 65	0046 4 65												
70	0046 04 70	0046 4 70	100	0046 104 70	200/500	0046 94 70	200							
75	0046 04 75	0046 4 75	200	0046 104 75	100									
80	0046 04 80	0046 4 80	100/200	0046 104 80	200	0046 94 80	200							
90	0046 04 90	0046 4 90	200											
100	0046 04 100	0046 4 100												
M 5	6	0046 05 6	2000	0046 5 6	100/250	0046 105 06	2000	0046 95 6	500/2000	0283 5 6	100	0293 5 6	500	
	8	0046 05 8		0046 5 8		0046 105 8	1000/2000	0046 95 8	500	0283 5 8	0293 5 8			
	10	0046 05 10		0046 5 10		0046 105 10	500/2000	0046 95 10	1000	0283 5 10	0293 5 10			
	12	0046 05 12	0046 5 12	100/250/1000	0046 105 12	1000	0046 95 12	1000/500	0283 5 12	100/500	0293 5 12			
	14	0046 05 14	0046 5 14	1000	0046 105 14			0046 95 14						
	16	0046 05 16	0046 5 16	100/250/1000	0046 105 16			0046 95 16		0283 5 16	100/500	0293 5 16	500	
	18	0046 05 18	0046 5 18	100/250	0046 105 18			0046 95 18		0283 5 18	500			
	20	0046 05 20	0046 5 20	1000	0046 105 20	500/1000	0046 95 20	1000	0283 5 20	100/500	0293 5 20	500		
	22	0046 05 22	0046 5 22		0046 105 22	1000	0046 95 22		0283 5 22	500				
	25	0046 05 25	0046 5 25	100	0046 105 25	100/1000	0046 95 25		0283 5 25	100/500	0293 5 25	200		
	28	0046 05 28	0046 5 28	1000	0046 105 28	1000	0046 95 28							
	30	0046 05 30	0046 5 30	100	0046 105 30	100/1000	0046 95 30		0283 5 30	100/500	0293 5 30			
	35	0046 05 35	0046 5 35	100/1000	0046 105 35	500	0046 95 35	200	0283 5 35	100	0293 5 35			
	40	0046 05 40	0046 5 40	0046 105 40	500		0046 95 40	500	0283 5 40	100/500	0293 5 40	200		
	45	0046 05 45	0046 5 45	0046 105 45	100		0046 95 45		0283 5 45	200	0293 5 45			
	50	0046 05 50	0046 5 50	0046 105 50	100		0046 95 50	0283 5 50	100	0293 5 50				
	55	0046 05 55	0046 5 55	200	0046 5 55	200			0283 5 55	200				
	60	0046 05 60	0046 5 60	500	0046 5 60	100	0046 105 60	200	0046 95 60	500	0283 5 60	100		
	65	0046 05 65	0046 5 65	200	0046 5 65	200								
	70	0046 05 70	0046 5 70								0283 5 70	200		
75	0046 05 75	0046 5 75	0046 105 75		100									
80	0046 05 80	0046 5 80								0283 5 80	200			
90	0046 05 90	0046 5 90												
100	0046 05 100	0046 5 100	100	0046 5 100	100									

Nenn-Ø d	Länge l mm	Stahl 4.8 blank Art.-Nr.	VE/St.	Stahl 4.8 vz., blau pass. Art.-Nr.	VE/St.	Stahl 4.8 vz., gelb pass. Art.-Nr.	VE/St.	Stahl 4.8 vernickelt Art.-Nr.	VE/St.	A2  Art.-Nr.	VE/St.	A4  Art.-Nr.	VE/St.						
M 6	6	0046 06 6	1000	0046 6 6	100/1000	0046 106 06	1000	0046 96 6	1000										
	8	0046 06 8		0046 6 8	100/500/1000	0046 106 08		0046 96 8											
	10	0046 06 10		0046 6 10	100/250/1000	0046 106 10		0046 96 10						200	0283 6 10	100	0293 6 10	200	
	12	0046 06 12		0046 6 12	1000	0046 106 12		0046 96 12						1000	0283 6 12		0293 6 12		
	14	0046 06 14		0046 6 14	1000	0046 106 14													
	16	0046 06 16		0046 6 16	100/250	0046 106 16		500/1000						0046 96 16	500/1000	0283 6 16	100	0293 6 16	200
	18	0046 06 18		0046 6 18	100/300	0046 106 20		300/1000						0046 96 20	1000	0283 6 20	100	0293 6 20	200
	20	0046 06 20		0046 6 20	100/300	0046 106 22		500						0046 96 22	500	0283 6 22	200	0293 6 22	200
	22	0046 06 22		0046 6 25	100/300	0046 106 25								0046 96 25		0283 6 25	100	0293 6 25	200
	25	0046 06 25		0046 6 28	500														
	28	0046 06 28	0046 6 30	100/300	0046 106 30	200/500	0046 96 30	500	0283 6 30	100	0293 6 30	200							
	30	0046 06 30	0046 6 32	500															
	32	0046 06 32	0046 6 35	200	0046 6 35	100	0046 106 35	500	0046 96 35	500	0283 6 35	100	0293 6 35	100					
	35	0046 06 35	0046 6 40		0046 106 40		0046 96 40	0283 6 40	0293 6 40										
	40	0046 06 40	0046 6 45		0046 106 45		0283 6 45	0293 6 45											
	45	0046 06 45	0046 6 50		0046 106 50		0046 96 50	0283 6 50	0293 6 50										
	50	0046 06 50	0046 6 55																
	55	0046 06 55	0046 6 60		0046 106 60		200	0046 96 60	200	0283 6 60	100		0293 6 60		100				
	60	0046 06 60	0046 6 65							0283 6 65	100								
	65	0046 06 65	0046 6 70		0046 106 70		100			0283 6 70			0293 6 70		100				
70	0046 06 70	0046 6 75	200																
75	0046 06 75	0046 6 80	200							0283 6 80	100		0293 6 80		100				
80	0046 06 80	0046 6 85	100																
85	0046 06 85	0046 6 90	100					0283 6 90	100										
90	0046 06 90	0046 6 95	200																
95		0046 6 100	100	0046 6 100	50														
100	0046 06 100																		
M 8	10	0046 08 10	500	0046 8 10	500	0046 108 10	500			0283 8 10	100								
	12	0046 08 12		0046 8 12	100	0046 108 12		0283 8 12											
	14	0046 08 14																	
	16	0046 08 16		0046 8 16	100	0046 108 16		500		0283 8 16		100		0293 8 16	100				
	18	0046 08 18																	
	20	0046 08 20		0046 8 20	100	0046 108 20		100/500		0283 8 20		100							
	22	0046 08 22																	
	25	0046 08 25		0046 8 25	500	0046 108 25		200		0283 8 25		100		0293 8 25	100				
	30	0046 08 30		0046 8 30	100/200	0046 108 30		0283 8 30		0293 8 30									
	35	0046 08 35		0046 8 35	100	0046 108 35		0283 8 35		0293 8 35									
	40	0046 08 40	0046 8 40	200	0046 108 40	0283 8 40													
	45	0046 08 45	0046 8 45			0283 8 45													
	50	0046 08 50	0046 8 50	100/200	0046 108 50	200	0283 8 50	0293 8 50	100										
	55	0046 08 55	0046 8 55																
60	0046 08 60	0046 8 60	200			0283 8 60	100												
65	0046 08 65	0046 8 65	100																
70	0046 08 70	0046 8 70																	
75	0046 08 75	0046 8 75	100																
80	0046 08 80	0046 8 80	200																
M 10	16	0046 010 16	200	0046 10 16	200														
	20	0046 010 20		0046 10 20															
	25	0046 010 25	200/500	0046 10 25															
	30	0046 010 30	200	0046 10 30															
	35	0046 010 35	100	0046 10 35	100														
	40	0046 010 40		0046 10 40															
	45	0046 010 45		0046 10 45															
	50	0046 010 50		0046 10 50															
60	0046 010 60	0046 10 60																	
70	0046 010 70		0046 10 70																
80	0046 010 80	50	0046 10 80	50															